

NOTE. ROD-EYE ORIENTATION NOT GUARANTEED

ELECTRICAL OPTIONS/ SPECIFICATIONS
 OUTPUT SUPPLY (NOM)
 'A' 0.5 - 4.5V RATIOMETRIC 5V
 SUPPLY CURRENT 12mA TYP. 20mA MAX.

CONNECTIONS: CABLE
 +Ve 3-CORE RED 5-CORE RED
 +SENSE (5-WIRE ONLY) - ORANGE
 0V BLACK BLACK
 -SENSE (5-WIRE ONLY) - GRAY
 OUTPUT WHITE BLUE
 BODY SCREEN SCREEN
 CABLE; 0.2mm², O/A SCREEN, PUR JACKET, SUPPLIED WITH 50cm
 OR REQUIRED LENGTH IN cm (15000cm MAX).
 STANDARD 3-CORE: BLACK Ø4mm JACKET e.g. L50
 OPTIONAL 5-CORE: BLUE Ø4.6mm JACKET e.g. LQ50

RANGE OF DISPLACEMENT FROM 0-5mm TO 0-800mm e.g. 76.
 BODY MATERIAL:- STAINLESS STEEL 316.

FURTHER OPTIONS:
 BODY CLAMP CODE 'P'
 TWO BODY CLAMPS CODE 'P2'
 CLAMP CONSISTS OF 2 PARTS AND
 REQUIRES 2 OFF M6x55 (MIN.) CAPHEAD SCREWS.

SPRUNG PUSH-ROD, ≤300mm:
 EXTENDED POSITION CODE 'R'. RETRACTED CODE 'S'
 PUSH-ROD FREE CODE 'V' - NOT AVAILABLE WITH CODES 'R' OR 'S'

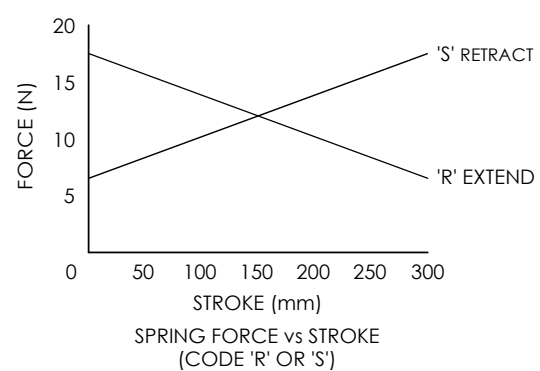
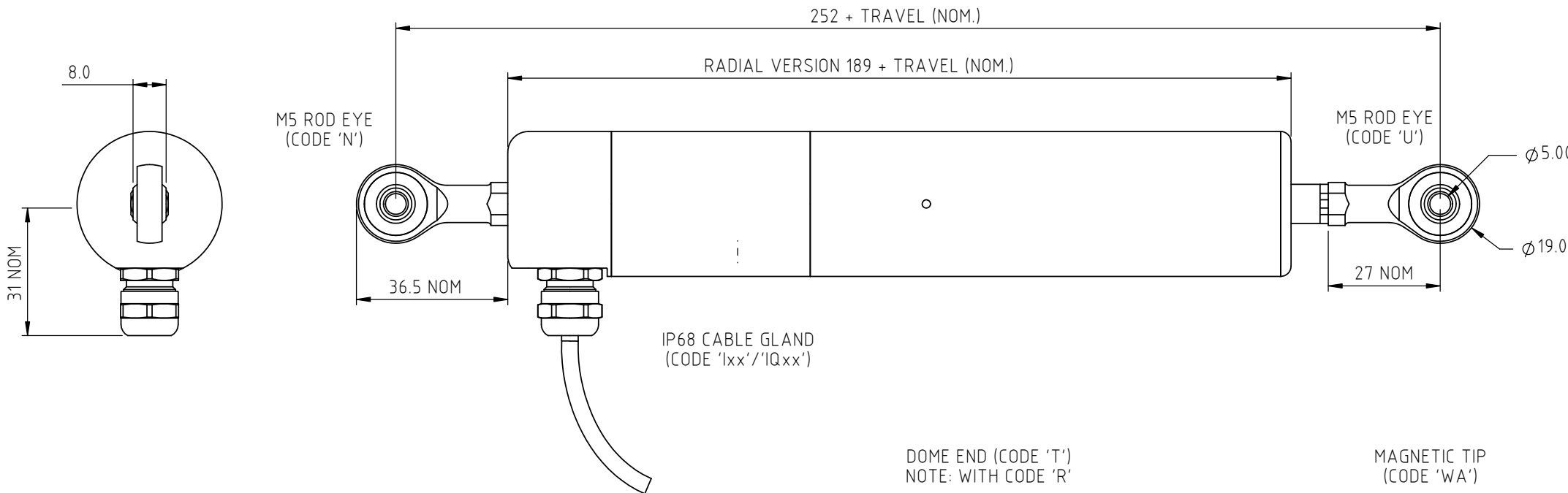
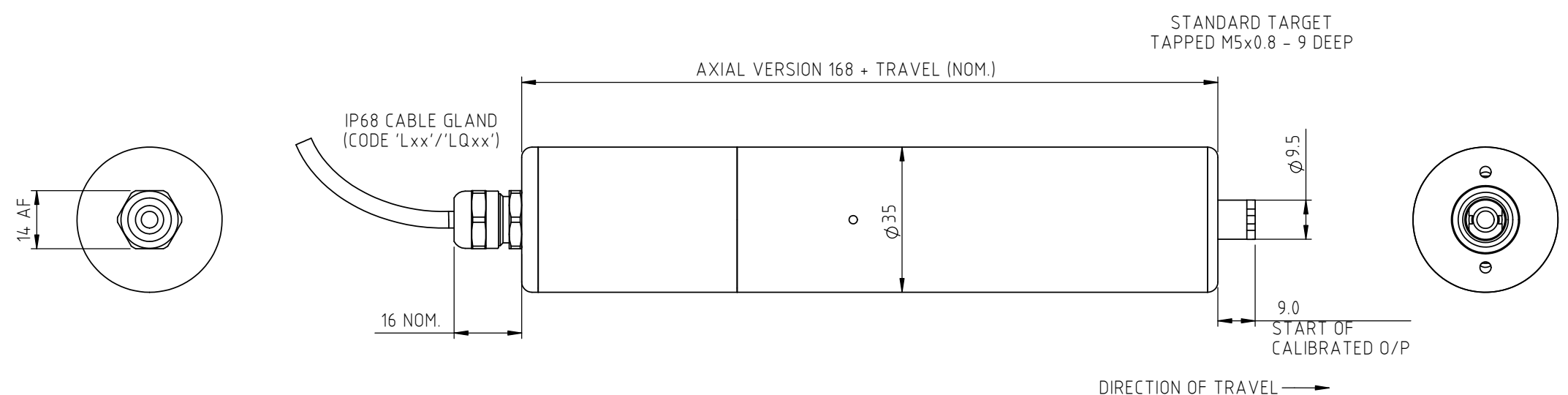

NOTE:- READ INSTALLATION SHEET M114-19 FOR FULL INSTRUCTIONS FOR USE.

ATEX / IECEx / UKEX APPROVED TO

Ex ia IIC T4 Ga (Ta= -40° to +80°C)
Ex ia IIIC T135°C Da (Ta= -40° to +80°C)
Ex ia I Ma (Ta= -40° to +80°C)
Ui 11.4V, Ii 0.2A, Pi 0.51W

APPROVED FOR USE IN CONJUNCTION WITH A GALVANICALLY ISOLATED BARRIER.

NOTE: APPROVAL ONLY APPLIES AT NORMAL ATMOSPHERIC PRESSURE!

MAXIMUM WORKING DEPTH: 100m (328 ft).
 WHERE THE FREE END OF THE CABLE IS TO BE TERMINATED IN A SUBMERGED POSITION, ADEQUATE SEALING MUST BE PROVIDED TO PROTECT CONNECTIONS.

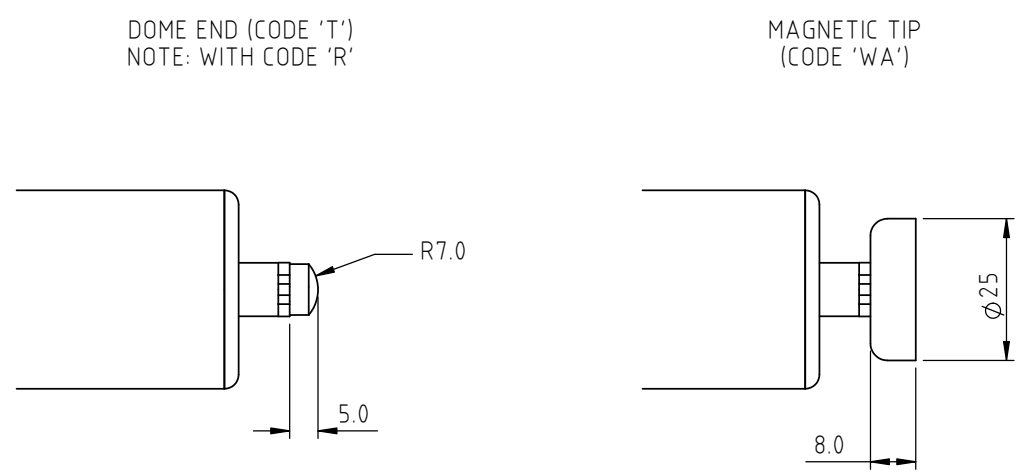

THE PUSH-ROD RETRACTS 4mm NOM. BACK FROM THE START OF CALIBRATED TRAVEL.
 THE PUSH-ROD EXTENDS 8mm NOM. BEYOND THE END OF CALIBRATED TRAVEL.
 SPRUNG OPTIONS:- CODE 'R': 1mm, CODE 'S': 2mm.
 CODE 'V': PUSH-ROD NOT RETAINED.

DRAWINGS NOT TO BE CHANGED WITHOUT REFERENCE TO THE CHANGE PROCEDURE.
 CHANGES TO PARTS USED IN INTRINSICALLY SAFE PRODUCT MUST BE APPROVED BY THE AUTHORISED PERSON.
 THIS IS AN UNCONTROLLED PRINT AND WILL NOT BE UPDATED.

REV	CHANGE HISTORY	DR'WN	DATE	CHK'D
G	RAN1311 - MAGNETIC TIP OPTION 'WA' ADDED	ASC	01/06/2023	ASC



APPROVED BY RDM	REV G		X ±0.4 X.X ±0.2 X.XX ±0.1 DIMs mm
DESCRIPTION M114 INTRINSICALLY SAFE SUBMERSIBLE STAND ALONE LINEAR POSITION SENSOR		DRAWING NUMBER M114-11	
SCALE 3:4	DRAWING NUMBER M114-11		
A3	SHEET 1 OF 1		



M114 SUBMERSIBLE STAND-ALONE LINEAR POSITION SENSOR INTRINSICALLY SAFE FOR HAZARDOUS MINING ENVIRONMENTS

- **Intrinsically safe for Mining to: Ex I/II M1/1GD**
- **Non-contacting inductive technology to eliminate wear**
- **Travel set to customer's requirement**
- **Compact and self-contained**
- **High durability and reliability**
- **High accuracy and stability**
- **Sealing to IP68 10bar/IP69K**



As a leading designer and manufacturer of linear, rotary, tilt and intrinsically safe position sensors, Positek® has the expertise to supply a sensor to suit a wide variety of applications.

Our intrinsically safe M114 incorporates electronics system EX07 which is ATEX / IECEx / UKEX approved for use in potentially explosive **gas/vapour, dust** atmospheres and **mining** environments. The M114 is an affordable, durable, high-accuracy position sensor. Derived from the M101, it is designed for applications where the sensor would be completely submerged during normal operation, it retains desirable features such as compact size, good sensor performance yet capable of working at pressure. The M114, like all Positek® sensors, provides a linear output proportional to travel. Each unit is supplied with the output calibrated to the travel required by the customer, from 5 to 800mm and with full EMC protection built in. The sensor is very robust, the body and push rod being made of stainless steel for long service life and environmental resistance. Overall performance, repeatability and stability are outstanding over a wide temperature range. The sensor is easy to install with mounting options including M5 stainless steel rod eye bearings and body clamps. The push rod can be supplied free or captive with female M5 thread, an M5 rod eye, dome end or magnetic tip. 1/4" rod eye option available. Captive push rods can be sprung loaded, in either direction, on sensors up to 300mm of travel. The M114 also offers a selection of mechanical and electrical options, environmental sealing is to IP68 10bar/IP69K.

SPECIFICATION

Dimensions

Body diameter	35 mm
Body length (Axial version)	calibrated travel + 168 mm
Body length (Radial version)	calibrated travel + 189 mm
Push rod extension	calibrated travel + 9 mm, OD 9.5 mm

For full mechanical details see drawing M114-11

Independent Linearity

$\leq \pm 0.25\%$ FSO @ 20°C - up to 450 mm
$\leq \pm 0.5\%$ FSO @ 20°C - over 450 mm

Temperature Coefficients

$< \pm 0.01\%/^{\circ}\text{C}$ Gain &
$< \pm 0.01\%$ FS/ $^{\circ}\text{C}$ Offset
> 10 kHz (-3dB)

Frequency Response

Infinite

Resolution

$< 0.02\%$ FSO

Noise

Intrinsic Safety

Ex I/II M1/1GD
Ex ia IIC T4 Ga (Ta= -40°C to 80°C)
Ex ia IIIC T135°C Da (Ta= -40°C to 80°C)
Ex ia Ma (Ta= -40°C to 80°C)

Approval only applies to the specified ambient temperature range and atmospheric conditions in the range 0.80 to 1.10 Bar, oxygen $\leq 21\%$

Sensor Input Parameters

Ui: 11.4V, Ii: 0.20A, Pi: 0.51W.

(without cable)

Ci: 1.16 μ F, Li: 50 μ H

(with cable)

Ci: 1.36 μ F, Li: 860 μ H with 1km max. cable

Environmental Temperature Limits (Non Icing)

Operating -40°C to +80°C

Storage -40°C to +125°C

Sealing

IP68 10bar/IP69K

EMC Performance

EN 61000-6-2, EN 61000-6-3

Vibration

IEC 68-2-6: 10 g

Shock

IEC 68-2-29: 40 g

MTBF

350,000 hrs 40°C Gf

Drawing List

M114-11

Sensor Outline

3D models, step or .igs format, available on request.

Do you need a position sensor made to order to suit a particular installation requirement or specification? We'll be happy to modify any of our designs to suit your needs - please contact us with your requirements.



For further information please contact:

www.positek.com sales@positek.com

Tel: +44(0)1242 820027 fax: +44(0)1242 820615

Positek, Andoversford Industrial Estate, Cheltenham GL54 4LB. U.K.

M114-17j

1 of 3



M114 SUBMERSIBLE STAND-ALONE LINEAR POSITION SENSOR INTRINSICALLY SAFE FOR HAZARDOUS MINING ENVIRONMENTS

Intrinsically safe equipment is defined as "equipment which is incapable of releasing sufficient electrical or thermal energy under normal or abnormal conditions to cause ignition of a specific hazardous atmosphere mixture in its most easily ignited concentration."

ATEX / IECEx / UKEX approved to;

- Ex I/II M1/GD
- Ex ia IIC T4 Ga (Ta= -40°C to 80°C)
- Ex ia IIIC T135°C Da (Ta= -40°C to 80°C)
- Ex ia I Ma (Ta=-40°C to 80°C)

Designates the sensor as belonging to; Groups I and II: suitable for all areas (**including mining**), Category M1/1 GD: can be used in areas with continuous, long or frequent periods of exposure to hazardous gas (Zones 2 to 0) and dust (Zone 20), equipment remains energised.

Gas / Vapour:

Protection class ia, denotes intrinsically safe for all zones

Apparatus group IIC: suitable for IIA, IIB and IIC explosive gas / vapour.

Temperature class T4: maximum surface temperature under fault conditions 135°C.

Dust:

T135°C: maximum surface temperature under fault conditions.

Ambient temperature range extended to -40°C to +80°C.

It is imperative Positek® intrinsically safe sensors be used in conjunction with a galvanic barrier to meet the requirements of the product certification. The Positek X005 Galvanic Isolation Amplifier is purpose made for Positek IS sensors making it the perfect choice. Refer to the X005 datasheet for product specification and output configuration options.

For cable lengths exceeding 10 metres a five wire connection is recommended to eliminate errors introduced by cable resistance and associated temperature coefficients.

ATEX / IECEx / UKEX approved sensors suitable for gas (X series) and dust (E series) applications, are also available from Positek.

M114	a	b	c	d	e	f	g	h	j
	Displacement	A	Connections	Option	Option	Option	Option	Option	Z000

a Displacement	Value
Factory set to any length from 0-5 mm to 0-800 mm (e.g. 0-254 mm)	254
b Output	
Supply V_{dc} (tolerance)	Output
+5V (4.5 - 5.5V)	0.5 - 4.5V (ratiometric with supply)
Supply Current 10mA typical, 12mA max.	A
c Connections	Code
Cable gland radial IP68 10bar/IP69K Pg7, 3-core cable	Ixx
Cable gland radial IP68 10bar/IP69K Pg7, 5-core cable	IQxx
Cable gland axial IP68 10bar/IP69K Pg7, 3-core cable	Lxx
Cable gland axial IP68 10bar/IP69K Pg7, 5-core cable	LQxx
Specify required cable length 'xx' in cm. e.g. L2000 specifies axial cable gland with 20 m of cable, 50 cm supplied as standard. Note! maximum length supplied 15000cm.	
d Body Fittings	Code
None default	blank
M5 Rod-eye bearing radial version only	N
e Body Clamps	Code
Body Clamps 1 pair	P
Body Clamps 2 pairs	P2

f Sprung Push Rod	Code
Not sprung default	blank
Spring extend	R
Spring retract	S
300 mm maximum displacement and captive push rod only.	
g Push Rod Fittings	Code
Female thread M5x0.8x9 deep default	blank
Dome end with spring extend option 'R'	T
M5 Rod-eye Bearing	U
Magnetic Tip	WA
h Push Rod	Code
Captive push rod retained default	blank
Non-captive push rod can depart body	V
j Z-code	Code
Calibration to suit X005 required	Z000
Tighter Independent Linearity; $\leq \pm xx\%$ FSO @20°C	
$\leq \pm 0.1\%$ 0 - 10 mm min. to 0 - 450 mm	Z650
$\leq \pm 0.25\%$ 0 - 451 mm to 0 - 600 mm	
$\leq \pm 0.5\%$ 0 - 601 mm to 0- 800 mm max.	
1/4" Rod eyes with options 'N' and/or 'U'	Z827

Output Characteristic - Standard

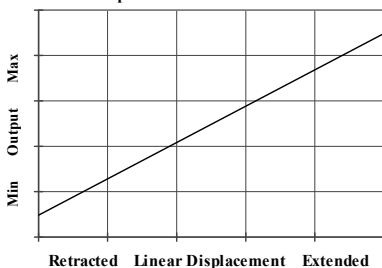

For further information please contact:

www.positek.com sales@positek.com

Tel: +44(0)1242 820027 fax: +44(0)1242 820615

Positek, Andoversford Industrial Estate, Cheltenham GL54 4LB. U.K.

M114-17j

2 of 3



Three or Five-Wire Mode Connection

FOR INTRINSICALLY SAFE SENSORS IN HAZARDOUS ATMOSPHERES

The aim of this document is to help readers who do not understand what is meant by three or five wire modes of connection between the galvanic isolation amplifier and sensor, and the factors behind them. It is by no means an in-depth technical analysis of the subject.

Whether opting for a pre-wired Positek® Intrinsicly Safe sensor or one with a connector, choosing the right mode of connection and cable to suit the application requires careful consideration.

Interconnecting cables are not perfect conductors and offer resistance to current flow, the magnitude of resistance[†] depends on conductors resistivity, which changes with temperature, cross sectional area[‡] and length. If the voltage were to be measured at both ends of a length of wire it would be found they are different, this is known as volts drop. Volts drop changes with current flow and can be calculated using Ohm's law, it should be noted that volts drop occurs in both positive and negative conductors. The effects of volts drop can be reduced by increasing the conductors cross sectional area, this does not however eliminate the effects due to temperature variation. There are instances where large cross-section cables are not practical; for example most standard industrial connectors of the type used for sensors have a maximum conductor capacity of 0.75mm², copper prices and ease of installation are other considerations.

This is important because the effects of volts drop can significantly alter the perceived accuracy of the sensor which is ratiometric i.e. the output signal is directly affected by the voltage across the sensor. Changes in temperature will also be seen as gain variation in the sensor output.

Three wire mode connections are common and are suitable in most cases with short or moderate cable runs. Applications that do not require a high degree of accuracy but have cable runs, say in excess of 10m, volts drop can be reduced by introducing a terminal box close to the sensor and using a larger cross-section cable for a majority of the cable run. Sensors supplied with three core cable are calibrated with the cable fitted which largely eliminates errors due to conductor resistance at room temperature however, as mentioned above, small gain errors due to temperature fluctuations should be expected.

Five wire mode connections have significant benefits as losses in the positive and negative conductors are compensated for by the galvanic isolation amplifier which can 'sense' the voltage across the sensor and dynamically adjust the output voltage so that the voltage across the sensor is correct. The effects of cable resistance and associated temperature coefficients are eliminated allowing for smaller conductors than a three wire connection for the same cable run. The amplifier can compensate for up to 15Ω per conductor with a current flow of 15mA, which is more than adequate for 150m of 0.25 mm² cable, longer lengths will require larger conductors.

For this reason Positek® recommends five wire connections for cable lengths exceeding 10 metres in 0.25 mm² cable to preserve the full accuracy of the sensor.

See illustrations below for examples of connecting a sensor to the galvanic isolation amplifier.

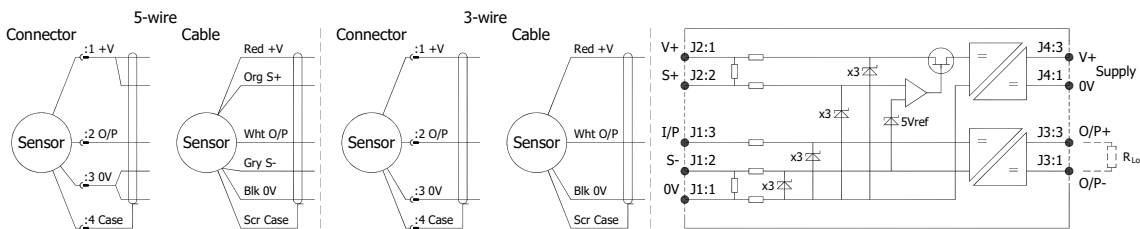

Cable Length (metres)	Up to 150	150 - 300	300 - 450	450 - 600	600 - 900	900 - 1000
Cross Section (mm ²)	0.25	0.5	0.75	1.0	1.5	2.0

The table above shows recommended conductor sizes with respect to cable length for both three and five wire connections, based on copper conductors. Three wire connections will introduce a gain reduction of 5% and a ±1% temperature dependence of gain over the range -40°C to +80°C for the cable temperature. (i.e. about -150 ppm/°C for the maximum lengths shown and less pro rata for shorter lengths.)

It should be noted that the maximum cable length, as specified in the sensor certification, takes **precedence** and **must not** be exceeded.

Positek® sensors are supplied with three core 0.25 mm² cable as standard, however five core 0.25 mm² cable can be supplied on request. The galvanic isolation amplifier is available as;

G005-*** for 'G' and 'H' prefix sensors
X005-*** for 'E', 'M' and 'X' prefix sensors

[†] $R = \rho L / A$ ρ is the resistivity of the conductor (Ωm) L is the length of conductor (m) A is the conductor cross-sectional area (m²).

[‡] It is presumed that direct current flow is uniform across the cross-section of the wire, the galvanic isolation amplifier and sensor are a dc system.



For further information please contact:

www.positek.com sales@positek.com

Tel: +44(0)1242 820027 fax: +44(0)1242 820615

Positek, Andoversford Industrial Estate, Cheltenham GL54 4LB. U.K.



Installation Information

M114 SUBMERSIBLE STAND-ALONE LINEAR POSITION SENSOR

INTRINSICALLY SAFE FOR HAZARDOUS MINING ENVIRONMENTS

ATEX / IECEx / UKEX Qualified to Intrinsic Safety Standard Certificate numbers SIRA 13ATEX2371X IECEX SIR 13.0154X CSAE 21UKEX2537X		Ex I/II M1/1GD Ex ia IIC T4 Ga (Ta = -40°C to +80°C) Ex ia IIIC T135°C Da (Ta = -40°C to +80°C) Ex ia I Ma (Ta = -40 to +80°C)	
Electronics Version	Output Description:	Supply Voltage: V _s (tolerance)	Load resistance:
EX07	0.5 - 4.5V (ratiometric with supply) [Output code 'A']	+5V (4.5 - 5.5V)	5kΩ min

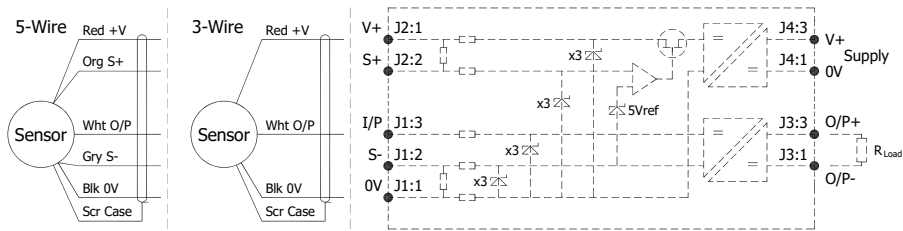

Putting Into Service: The sensor must be used with a galvanic isolation barrier designed to supply the sensor with a nominal 5V and to transmit the sensor output to a safe area. The barrier parameters must not exceed:-

U_i = 11.4V **I_i = 0.20A** **P_i = 0.51W**
C_i = 1.36μF* **L_i = 860μH*** ('Ixx', 'IQxx', 'Lxx' or 'LQxx' options) *Figures for 1km cable
C_i = 1.16μF **L_i = 50μH** (without cable)

The sensor is certified to be used with up to **1000m** of cable, cable characteristics must not exceed:-

Capacitance: ≤ 200 pF/m or max. total of: 200 nF
 Inductance: ≤ 810 nH/m or max. total of: 810 μH

Approval only applies to specified ambient temperature range and atmospheric conditions in the range: 0.80 to 1.10 Bar, oxygen ≤ 21%.

The performance of the sensor may be affected by voltage drops associated with long cable lengths; For cable lengths exceeding 10 metres a five wire connection is recommended to eliminate errors introduced by cable resistance and associated temperature coefficients.

N.b. Where the free end is to be terminated in a submerged position adequate sealing must be provided to protect connections.

Special Condition for Safe Use:

The apparatus does not meet the 500 V r.m.s dielectric strength test between circuit and frame, in accordance with clause 6.3.13 of IEC 60079-11:2011. This must be taken into consideration on installation.

The free end of the cable shall be appropriately terminated for the zone of use.

Under certain extreme circumstances, the non-metallic and isolated metal parts incorporated in the enclosure of this equipment may generate an ignition-capable level of electrostatic charge. Therefore the equipment shall not be installed in a location where the external conditions are conducive to the build-up of electrostatic charge on such surfaces. This is particularly important if the equipment is installed in a zone 0 location. In addition, the equipment shall only be cleaned with a damp cloth.

Use: The sensor is designed to measure linear displacement and provide an analogue output signal.

Assembly and Dismantling: The unit is not to be serviced or dismantled and re-assembled by the user.

Maintenance: No maintenance is required.

Mechanical Mounting: Depending on options; body can be mounted by rod eye bearing or by clamping the sensor body - body clamps are available, if not already ordered. Target by M5x0.8 female thread, rod eye bearing or magnetic tip. It is assumed that the sensor and target mounting points share a common earth.

Output Characteristic: Target is extended 9 mm from end of body at start of normal travel. The output increases as the target extends from the sensor body, the calibrated stroke is between 5 mm and 800 mm.

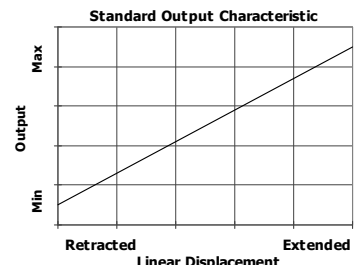

Incorrect Connection Protection levels: Not protected – the sensor is **not** protected against either reverse polarity or over-voltage. The risk of damage should be minimal where the supply current is limited to less than 50mA.



For further information please contact:
www.positek.com sales@positek.com
 Tel: +44(0)1242 820027 fax: +44(0)1242 820615
 Positek, Andoversford Industrial Estate, Cheltenham GL54 4LB. U.K.