

# POSITAL

## FRABA

KCD-BC0XB-XX17-U01C-XXX

Distributed by  
**Everight Position**  
www.evrtp.com  
856 727 9500



### IXARC Kit Encoder With BISS C Interface

- ▶ Kit Encoder for Integration to Motors, Robots and Machinery<sup>1</sup>
- ▶ Electrical Resolution: Up To 17 bit
- ▶ Multiturn Range: Up To 32 Bit
- ▶ 36 mm Diameter
- ▶ Energy-Harvesting-System Based On Wiegand Effect
- ▶ No Battery – No Maintenance
- ▶ Easy Installation with Self-Calibration

Also available with SSI

## 1. Interface

Interface	BiSS C
Programming Functions	Electronic Calibration, Wiegand Sensor Test, Preset
Min Interface Cycle Time	50 $\mu$ s

## 2. Electrical Data

Supply Voltage	4.75-15 VDC
Power Consumption	$\leq$ 0.3 Watt
Start-up time	Max 100 ms
Clock Input	RS 422
Clock Frequency	KCD-BC01B: 300 kHz - 10 MHz KCD-BC03B: 80kHz - 10MHz
Reverse Polarity Protection	Yes
Short Circuit Protection	Yes
MTTF	20 years (estimated for max. operational temperature)
Max. Permissible Electrical Speed	12.000 RPM
EMC	Kit encoder is a sub-assembly and not considered to be an independent system, therefore compliance with CE requirements has to be ensured by the integrator for the overall set-up.

<sup>1</sup> The use of these kit encoders for the production of industrial rotary encoders is prohibited. Applications in rotary encoders are protected by several worldwide patents (such as WO 2004/046735 A1) and require licensing.

# POSITAL

## FRABA

KCD-BC0XB-XX17-U01C-XXX

### 3. Sensor

Singleturn Technology	Magnetic
Electrical Resolution Singleturn	17 bit
Multiturn Technology	Self powered magnetic pulse counter (no battery, no gear)
Multiturn Range	KCD-BC03B-1617-U01C-XXX – 16 bit KCD-BC03B-0017-U01C-XXX – single turn
Accuracy (INL)	$\pm 0.0878^\circ$ ( $\leq 12$ bit) measured after calibration at room temperature
Counting Direction (Default)	Clockwise shaft movement (front view on shaft)

### 4. Environmental Specifications

Operating Temperature	-40 °C (-40 °F) – +105 °C (221 °F)
Shock Resistance	$\leq 200$ g (half sine 6 ms, EN 60068-2-27)
Permanent Shock Resistance	$\leq 20$ g (half sine 16 ms, EN 60068-2-29)
Vibration Resistance	$\leq 30$ g (10 Hz – 1000 Hz, EN 60068-2-6)

### 5. Mechanical Data

Top Shield Material	Steel
Top Shield Coating	Cathodic corrosion protection
Stator Type	POSITAL standard
Rotor Type	POSITAL standard

### 6. Electrical Connection

Connection Orientation	Axial
Connector	JST BM08B-GHS-TBT

# POSITAL

## FRABA

KCD-BC0XB-XX17-U01C-XXX

### 7. Connection Plan

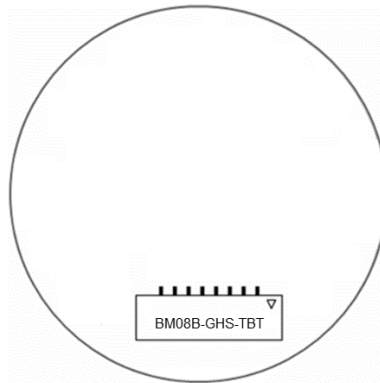

Pin	Signal
1	GND
2	Preset (default 0 position value)
3	Config (Kit Control box, serial communication)
4	Data + (SLO+)
5	Data - (SLO-)
6	CLOCK - (MA-)
7	CLOCK + (MA+)
8	VCC

### 8. Dimensional Drawing

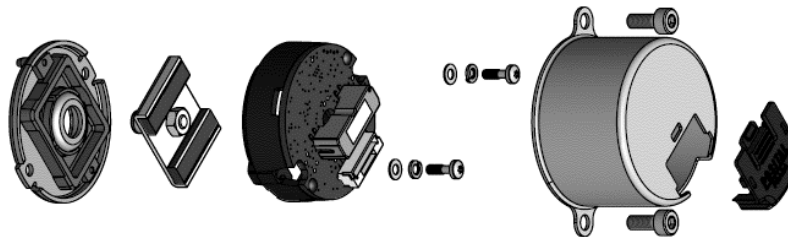

This kit version contains 4 main parts to be assembled from left to right side: shielding, magnet, carrier with PCB and Top Shield. In version KCD-BC03B-XX17-U01C-xxx, carrier already has pre-mounted screws.

# POSITAL

## FRABA

KCD-BC0XB-XX17-U01C-XXX

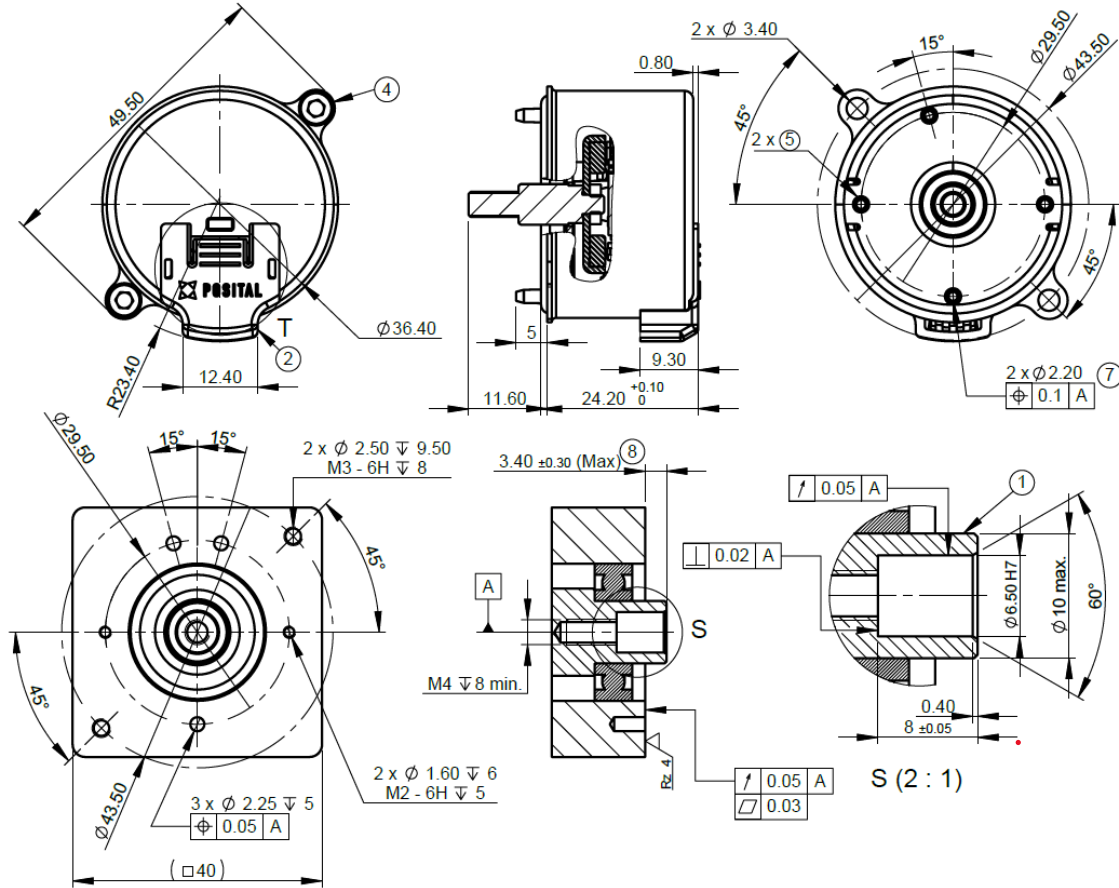

**A** = Center of Rotation

① = Different Shaft Sizes can be adapted

② = Plastic cover, "Detail view T" without cover.

④ = Screw ISO 4762 – M3 x 8 – 8.8, tightening torque  $1 \pm 10\%$  Nm

⑤ = Screw ISO 14583 – M2 x 7 – A4, tightening torque  $0.3 \pm 10\%$  Nm

⑦ = Centering Pins

⑧ = Including static and dynamic tolerances, in order to keep the specified accuracy, the dynamic part of the tolerance need to stay below  $\pm 0.1$  mm (movement of shaft after calibration)

- All dimension in [inch] mm. This drawing and the information contained is for general presentation purposes only. Please refer to the "Download" section for detailed technical drawings

## 9. Interface

### Preset Function

The preset function can be used to adapt the encoder position to the mechanical alignment of the system. By performing a preset, the actual position value of the encoder is set to the desired preset value. The preset can be triggered via hardware or software. See manual for more detailed information.

# POSITAL

---

## FRABA

KCD-BC0XB-XX17-U01C-XXX

### Config Pin

The config pin is used for serial data communication. Via this interface an optional re-calibration and WIEGAND pulse testing of the kit encoder can be conducted after motor installation. Also, the preset value can be applied as a software command. The protocol for communication is described in the manual. As alternative a graphical user interface with a Kit Control Box can be used for easy configuration and hardware setup, see website for more details.

<https://www.posital.com/en/products/kit-encoders/kit-control-box.php>

### 10. Version Space

KCD-BC03B-1617-U01C-JAQ	carrier screws pre-assembled, PCB connector exit
KCD-BC03B-1617-U01C-2RW	carrier screws pre-assembled, PCB connector exit, 2 m PVC cable accessory
KCD-BC03B-0017-U01C-JAQ	single turn, carrier screws pre-assembled, PCB connector exit
KCD-BC03B-0017-U01C-2RW	single turn, carrier screws pre-assembled, PCB connector, 2 m PVC cable accessory
KCD-BC01B-1617-U01C-JAQ*	PCB connector exit
KCD-BC01B-1617-U01C-2RW*	PCB connector exit, accessory 2 m PVC cable

\* Product life cycle – exiting.

### Contact

FRABA America  
T +1 609 750-8705  
✉ [info@posital.com](mailto:info@posital.com)

FRABA EMEA  
T +49 221 96213-0  
✉ [info@posital.eu](mailto:info@posital.eu)

FRABA Asia  
T +65 6514 8880  
✉ [info@posital.sg](mailto:info@posital.sg)

© FRABA B.V., All rights reserved. We do not assume responsibility for technical inaccuracies or omissions. Specifications are subject to change without notice.

Distributed by  
Everight Position  
[www.evrtp.com](http://www.evrtp.com)  
856 727 9500